

# Operation and Maintenance Guide for 48mm Composite Door

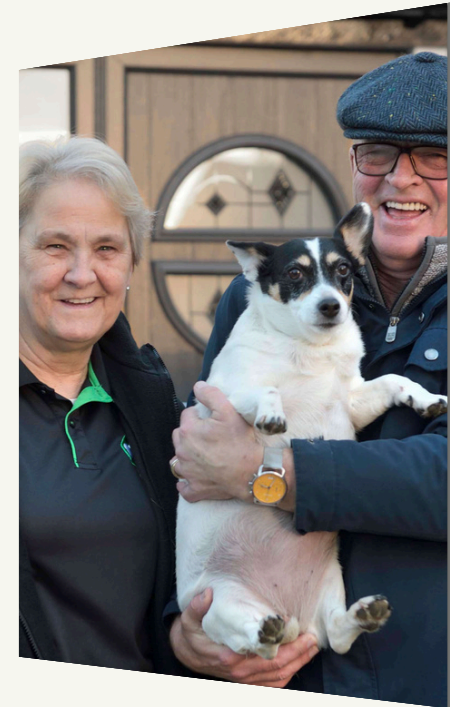

# Maintenance Instructions

## CYLINDER LOCKS

Lubricate 6 monthly using Dry Silicone spray

1. Apply 4 drops on each side of the key
2. Place the key in the lock & move back & forth 10 - 15 times to lubricate the cylinder
3. Repeat at least once a year, or when necessary

DO NOT USE WD40 or 3-in-1 oil

## MULTIPOINT LOCKS

- Wipe the door lock and keeps down with a clean damp cloth to remove dirt/grit
- Do not use household chemical cleaners or abrasive cleaners
- Do not use any cleaners which may affect the corrosion resistance of the product
- Avoid acid or ammonia-based cleaners & wipe dry after cleaning
- Twice per year apply petroleum jelly to all "contact" areas of Lock & Keeps as
- shown (Grease Points)
- Periodically inspect all fixings are secure. Any loose fixings should be tightened by a suitably qualified person

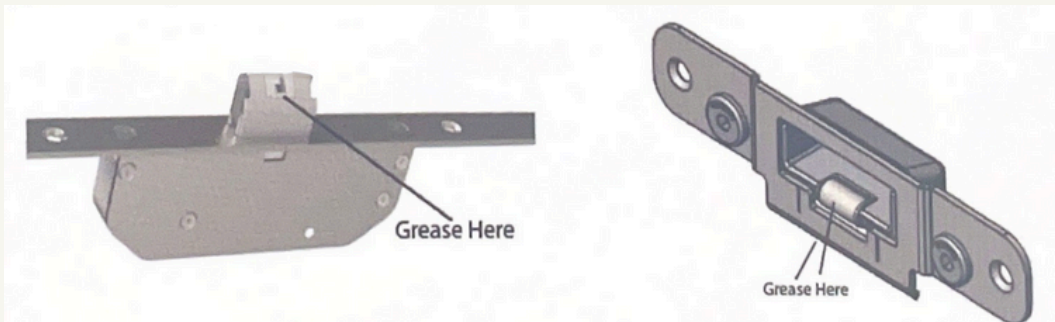

## DOOR FURNITURE (NOT STAINLESS STEEL)

For continued protection of the quality finish and appearance of all Fab & Fix hardware (letter plates, Handles, Knockers & Hinges) routine cleaning must be carried out, wash the hardware with a very mild soapy water and a cloth - making sure to dry well afterwards.

Moving parts should also be lightly lubricated using 3 in 1 oil at least twice a year. This procedure is particularly essential if products are installed within a 25-mile radius of coastal areas or close proximity to a building site or large industrial area, where more frequent cleaning may be required to prevent the accumulation of corrosive contaminants.

---

## DOOR FACES & FRAME

Using only soapy water and a sponge, wipe down the faces of the door and frame and immediately dry them using a towel, this should be repeated every month.

## 316 STAINLESS STEEL HARDWARE

To help you care for the BLUTM product range please follow the guidelines below. During installation and if building work is being carried out the hardware should be covered to protect it from dust, dirt and scratching. Immediately after fitting and installation Product should be cleaned using a soft cloth and mild soapy water then dried immediately with a clean, soft cloth.

## MONTHLY CARE AND MAINTENANCE

Clean regularly with a soft, dry cloth or duster. Rubbing or wiping should be carried out in the direction of the polish/finishing lines, not across them.

Product should be washed monthly using a soft cloth and mild soapy water then dried immediately with a clean, soft cloth - especially if fitted on or near the coast, fingerprints can be removed by washing product as above.

## SIX MONTHLY CARE AND MAINTENANCE

Stainless steel finish should be cleaned using the Comp Door Stainless Steel Renovation Kit at least every six months to help maintain this product stay in pristine condition. Lubricate any moving parts with a suitable PTFE Grease. Comp Door Stainless Steel Renovation Kits are available from our website.

### Please Note

- DO NOT use oily rags or greasy cloths when wiping the product surface
- DO NOT use bleach, abrasive cleaners, caustic or acid-based cleaning materials or detergents containing chloride, or any strong household cleaning products
- DO NOT use abrasive materials, files or other hard objects against the product surface
- This product should be protected from dust and dirt during any construction work
- If a softer metal, such as a ring or a key, marks the surface, it is possible that some of the metal may have been left on the surface. In this case, use a soft cloth and mild, non-acidic cleaner to remove the soft metal deposit

# Installation/replacement

---

## Pre-installation checks

Pre-installation checks: Before commencing any installation work, the sizes, types, and conditions of all door sets should be checked against both the survey sizes as well as the actual aperture sizes. The doorset specification, including hardware, glazing and door style, should be checked against the order acknowledgement provided by Sliders UK. Before discarding any packaging for ancillary components that may be supplied loosely, check that all required ancillary components are accounted for. NOTE: composite door sets must be stored in a dry location before installation. Prolonged exposure to moisture may invalidate Sliders UK's product guarantee.

## General

The importance of installing doorset outerframes plumb and square within the aperture, without twist, racking or distortion of any member, cannot be overemphasised. Repeatedly check the squareness and alignment of the outerframe during the process of installation.

## Positioning of doorsets

The positioning of the new frame in the aperture is fundamental to the success of the installation. In general, the replacement doors shall:

- Bridge to cavity.
- Cover the DPC.
- Be sat back as far as possible in the aperture to minimise exposure to the elements.

## Fixing method

Fixing methods will be influenced by movement:

- The presence or absence of a wall cavity.
- The nature of any cavity.
- The relative positions of the frame and cavity.
- The position of the plaster line, and the need to preserve the interior decorations.
- The design of the reveal.

## Fixing method

Fixing methods will be influenced by movement:

- The presence or absence of a wall cavity.
- The nature of any cavity.
- The relative positions of the frame and cavity.
- The position of the plaster line, and the need to preserve the interior decorations.
- The design of the reveal.

## Fixings

There are two principal methods of fixing available:

- Through-frame fixings.
- Lug fixings.

As a general rule, only through-frame fixings are recommended for fixing of plastic outer frame composite door sets.

Through-frame fixings should be plastic sheathed of minimum 100mm length, and shall penetrate a minimum of 50mm into the substrate.

The head of any through-frame fixing must be seated beneath the outer wall of the plastic outer frame member within the hollow chamber to prevent distortion or cracking of the frame.

A larger hole than that required for the fixing will need to be drilled in the outermost wall of the plastic outer frame member only, into which a cover cap should be inserted.

NOTE: other proprietary mechanical fixing methods are available. Prior to their use, it shall be determined that these are satisfactory by obtaining suitable third party assessment.

**Fig 1: Acceptable positioning of frame fixings**

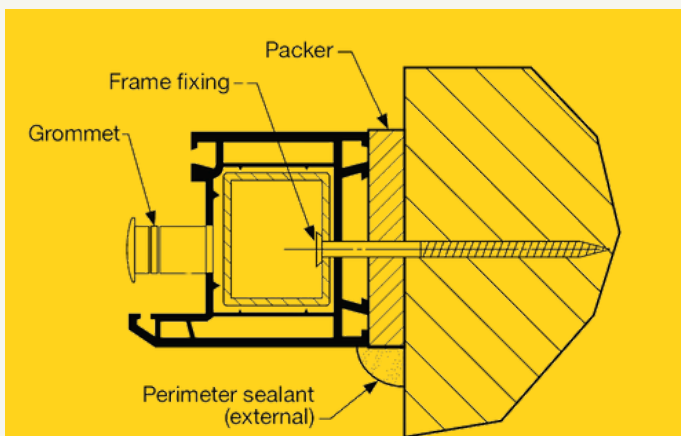
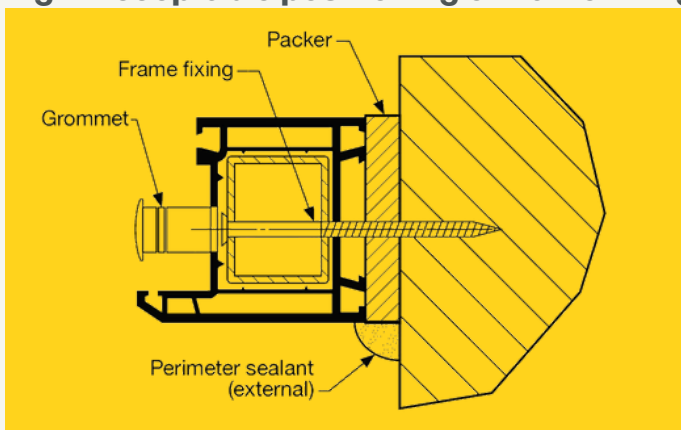

## Fixing distances

Generally, all four sides of the frame shall be secured using the following guidelines to determine the fixing spacings:

- Corner fixings should be a minimum of 150mm and a maximum of 250mm in from the external corner.
- No mullion or transom fixings should be closer than 150mm, or further than 250mm from the centre line of a mullion or transom.
- Intermediate fixings should be at centres no greater than 600mm.
- There must be a minimum of 3 fixings on each jamb - Fig.2 below illustrates fixing positions.

NOTE: if it is impossible to find a suitable fixing position, then the nearest possible fixing should be used.

**Fig 2: Fixing positions**

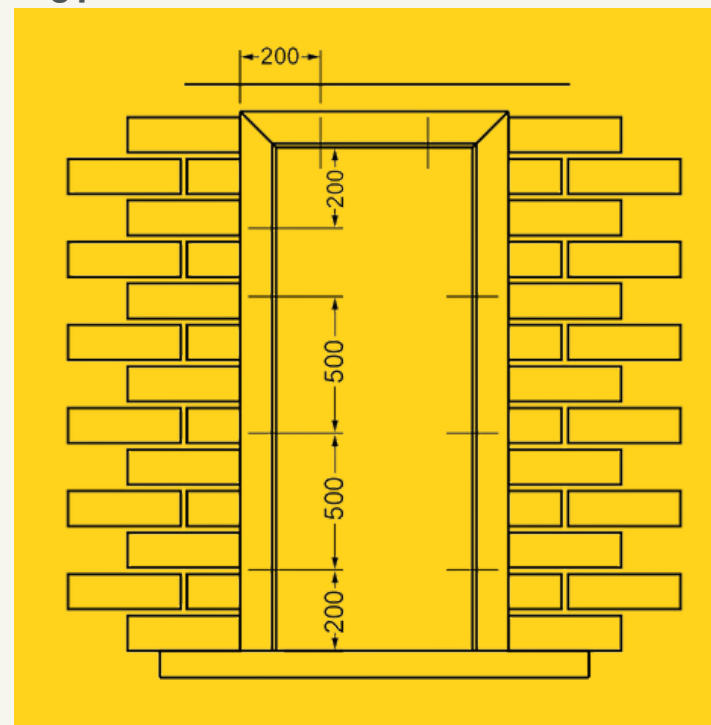

# Installation/replacement

## Use of installation packers

Appropriately sized installation packers shall be used adjacent to fixing positions to prevent outer frame distortion during installation. Installation packers should be incompressible, resistant to rot or corrosion, and span the full width of the outer frame profile. The fixings should be tightened to hold the frame securely against the packers. Take care not to over-tighten the screws and distort the frame. Apply a small amount of silicone mastic to the shanks and heads of fixings that pass through the outer frame to ensure that no water penetrates into the frame.

NOTE: packers shall be used adjacent to hinge/locking points.

## Foam fixing at the head

Foam fixing with polyurethane (PU) foam products at the head of the frame is discouraged and shall not be used for combination frame doorsets or fire doorsets.

NOTE: fewer installation problems arise if heads are fixed with mechanical fixings in accordance with these rules.

## Finishing off and making good - General

Efforts must be made during installation to ensure that debris such as wet plaster does not foul drainage paths nor impair operation of hardware. Neither sand and cement, nor plaster should be used to fill the gap between the frame and the structural opening. All protective films placed on the outerframe profiles and door facings should be removed as soon as the installation is finished, and prior to perimeter sealing.



# Perimeter Sealing

---

## General

The purpose of a perimeter sealant is to prevent water and air leakage between the aperture and the doorset.

## Non-fire resisting doorsets

No joint width shall be designed to be less than 5mm. Local variations in the line of the brickwork may create gaps greater than 5mm, the following examples illustrate common cases for filling these gaps.

## Sealing gaps up to 6mm

For non-fire-resisting doorsets, gaps up to 6mm in width can be sealed solely with a ribbon of silicone sealant. In all cases, the sealant should fill the gap to a depth no less than the width of the gap; a backing strip may be used to limit the amount of silicone used.

Backing strips can be either foam, compressible, or expandable strips, or 'in-situ' expanded foam, Any such materials must be compatible with plastic outerframes.

Priming of either the substrate or the frame is generally unnecessary when using quality sealants. However if the substrate is friable, then primer may be applied to the aperture surface to ensure adequate bonding.

## Sealing gaps between 6mm and 15mm

When sealing gaps between 6mm and 15mm, the use of a backing material is essential. This is also needed when the gap varies such that locally it exceeds 6mm.

## Sealing gaps over 15mm

Design widths above 15mm are not recommended and should not be necessary in UK conditions. Where this is due to mis-measure or irregular brickwork, reduce the gap to the design joint width using packing pieces.

## Sealing at heads

There should be an expansion gap between 5mm and 10mm at the head of the frame.

## Drainage

When sealing perimeter joints take care to ensure any drainage channels are not blocked or obstructed.

# Final Inspection

## Checklist

After installation, a final inspection should be carried out to ensure that the installation is of the highest standard. There should be a formal procedure for checking the installation, which should use a checklist to ensure that all relevant points are checked.

It is advisable that these checks are carried out in the presence of the client. It is good practice to ensure that the customer is familiar with the method of operation of the installed door sets.

## Doorset operation and maintenance

Operating features such as key locks, hook-bolts and latches shall be checked and should be demonstrated so that the client and tenant know how to use them. This is especially important in the case of exits that may be used in fires.

Final Inspection Checklist	
Area to be checked	Ok?Yes/No
<b>Visual Appearance</b>	
1. Doorsets installed plumb, square and vertical?	
2. Exposed faces free from surface damage?	
3. Doorset clean and all protective film removed?	
4. Check for weld cracks, clean & consistent shadow grooves	
5. Check for damage to surrounding aperture	
6. Check all internal trims installed correctly	
7. Check site clean and all debris removed	
<b>Glazing</b>	
1. Glazing as specified?	
2. No cracks, scratches on glass, or signs of sealed unit failure?	
3. Obscure glasses oriented correctly?	
<b>Doorset Operation</b>	
1. Door leaf opens & closes correctly?	
2. No air gaps between frame seal and door leaf?	
3. No scraping/rubbing between hooks and strikers?	
4. When doors slam, no mullion bounce, nor outer frame movement?	
5. All hardware correctly lubricated?	
6. All hardware attached with correct number of fixings?	
<b>Fixing</b>	
1. Through-frame fixings used at correct distances?	
2. Fixing heads located within frame profile and cover caps filled?	
<b>Sealing</b>	
1. Sealant joints have smooth finish, and are of correct shape?	
2. Sealant to be continuous around frame run?	
3. No excess sealant to be present on frame faces?	
<b>Drainage</b>	
1. Threshold drainage channels free from obstructions?	
2. Sub-sill end caps in place, and attached firmly?	





WWW.VALUEDOORS.CO.UK | PHONE 020 4587 8300

