

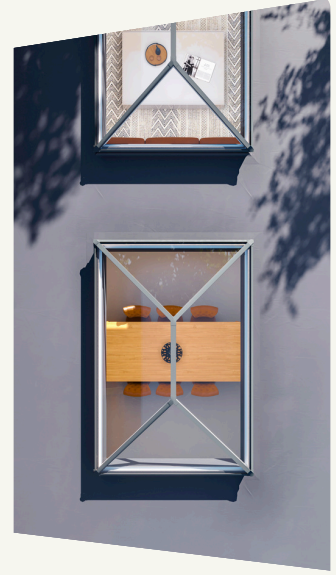

Value doors[®]
& windows

Roof Lantern Installation Guide

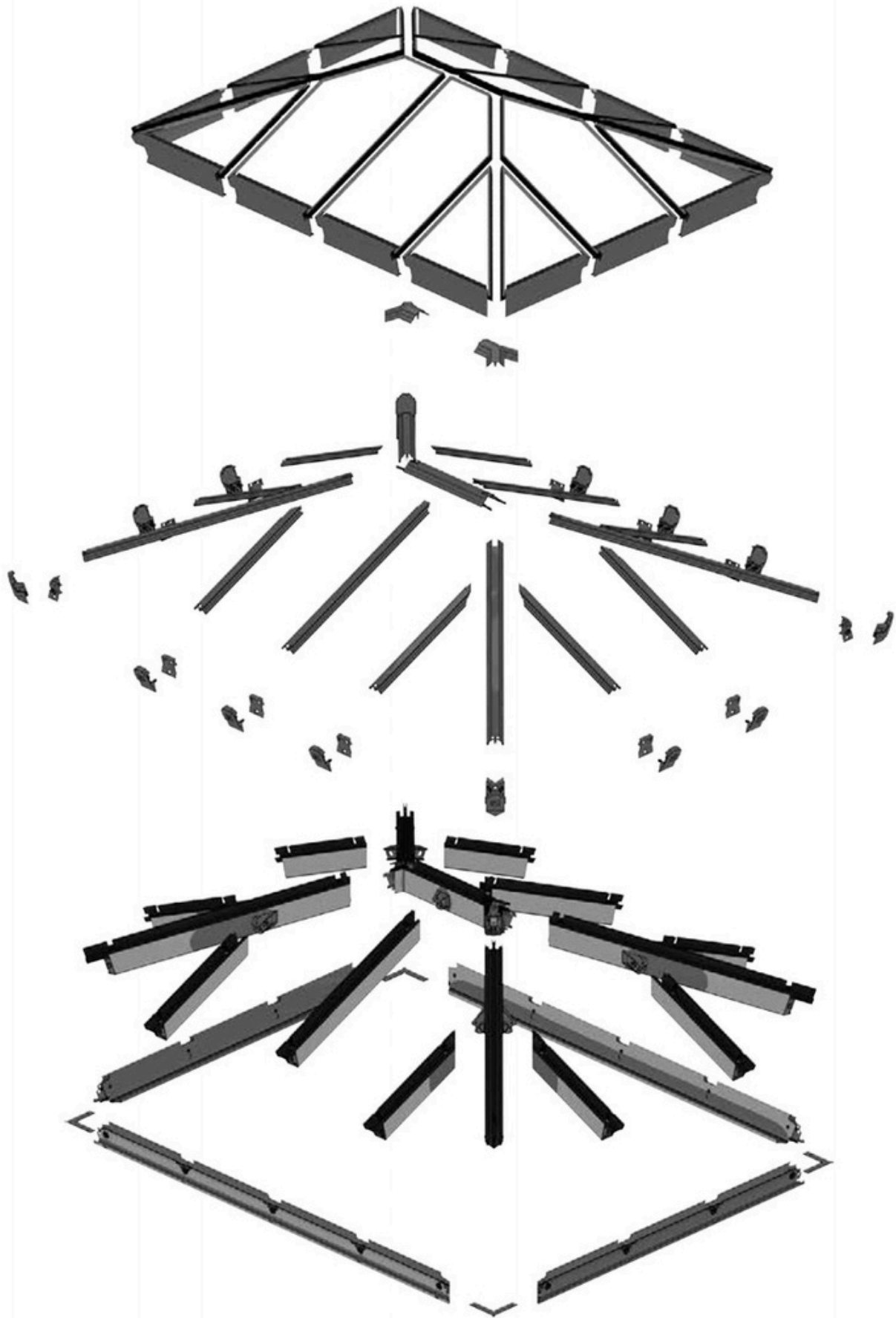



TOOLS REQUIRED



Cordless
Screwdriver



5mm Hex Bit
(Supplied)

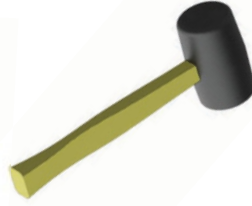

Soft
Mallet



Wire
Cutters



Sealant

PACKAGING CONTENTS



Eaves
Beams



Ridge



Hips

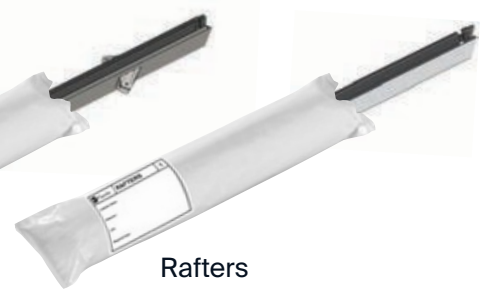

Rafters



5mm Hex
Bit



Rafter Outer
End Cap



Rafter Inner
End Cap



Hip Outer
End Cap



Hip Inner
End Cap



Eaves Beam
Corner Bracket



Boss Top Cap



M8x60mm
Rafter Bolts



M8x70mm
Hip Bolts



M8x20mm
Isolating Collar
Bolts



Tapered
Washers



Ball
Finial



4.8x63mm
Eaves Beam
Screws



Support
Block



Fir Tree
Clips



Tie-Wrap

EAVES BEAM

1

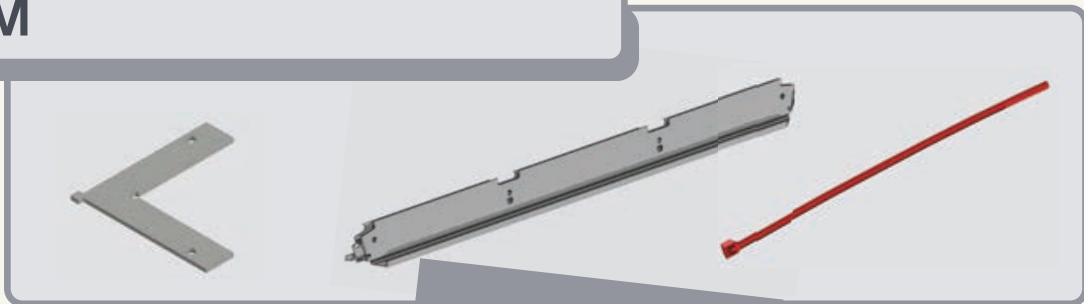

1 Slide together using corner brackets

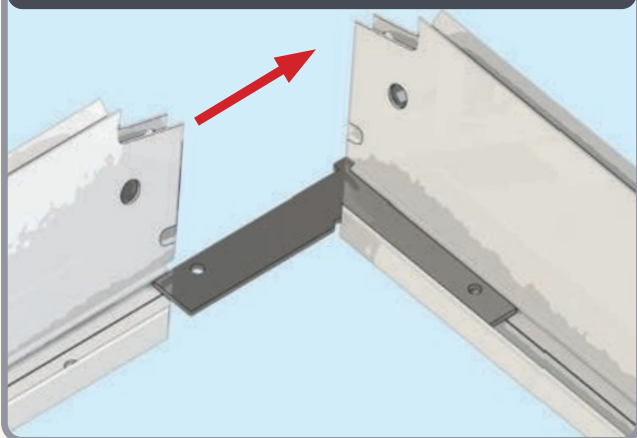

2 Temporarily secure corners with tie-wraps

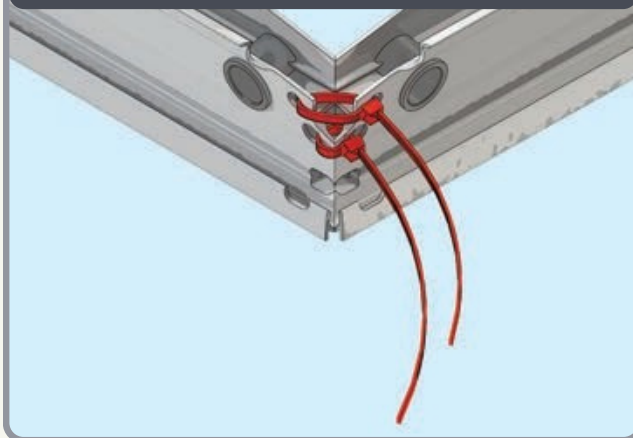

Ensure corner is closed up tightly

APPLYING SEALANT

2



Apply sealant generously **ONLY** where shown

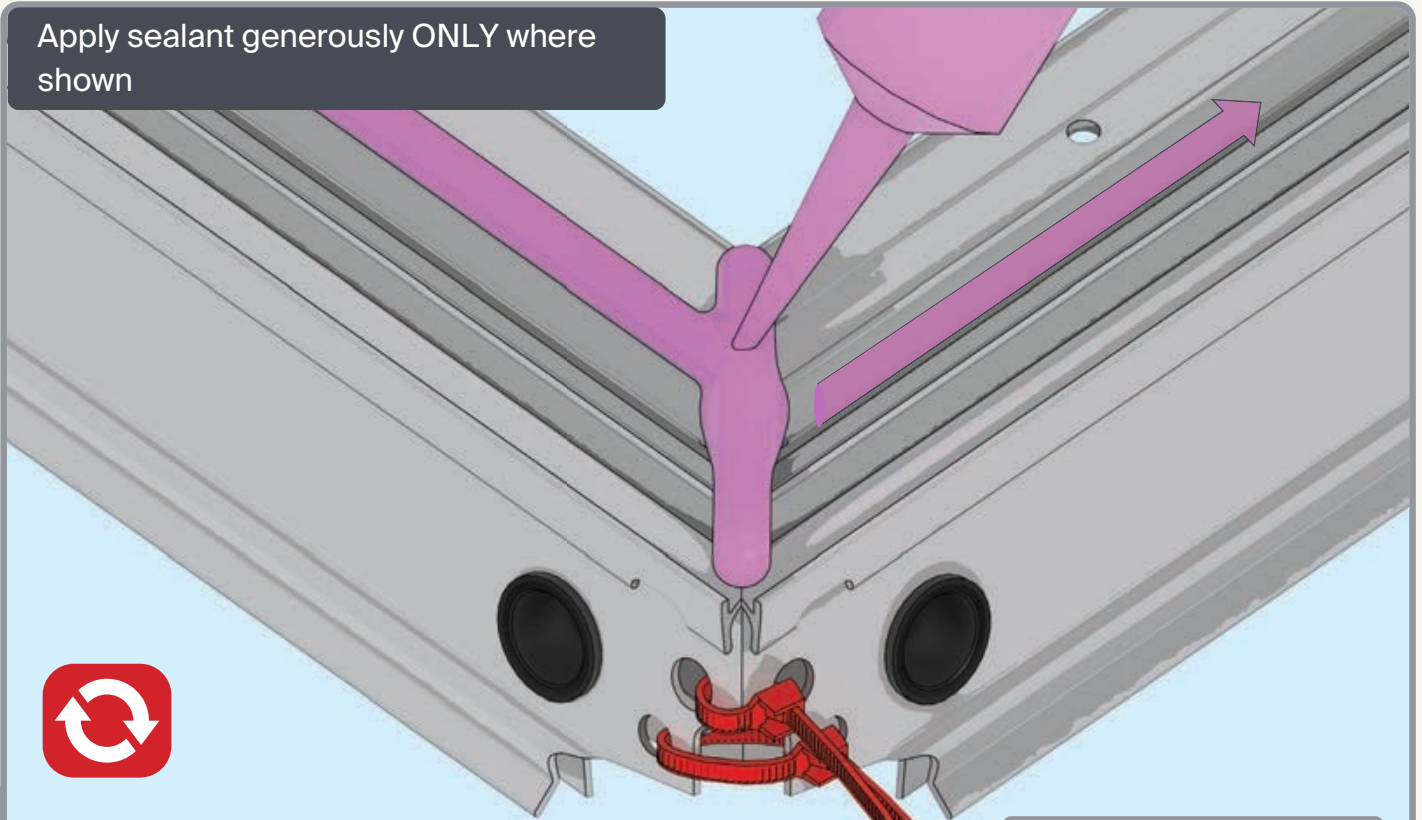

Corner position of sealant



• DO NOT screw down yet • Only apply sealant where indicated



• DO NOT apply sealant to the gap between the upstand and the eaves beam, this will block the drainage

upstand

SPIDER ASSEMBLY

3

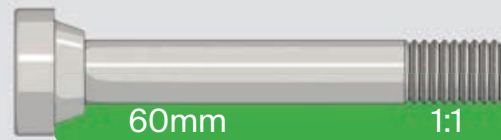

1 Secure hips to boss using 70mm bolts

2 Secure rafters using 60mm bolts

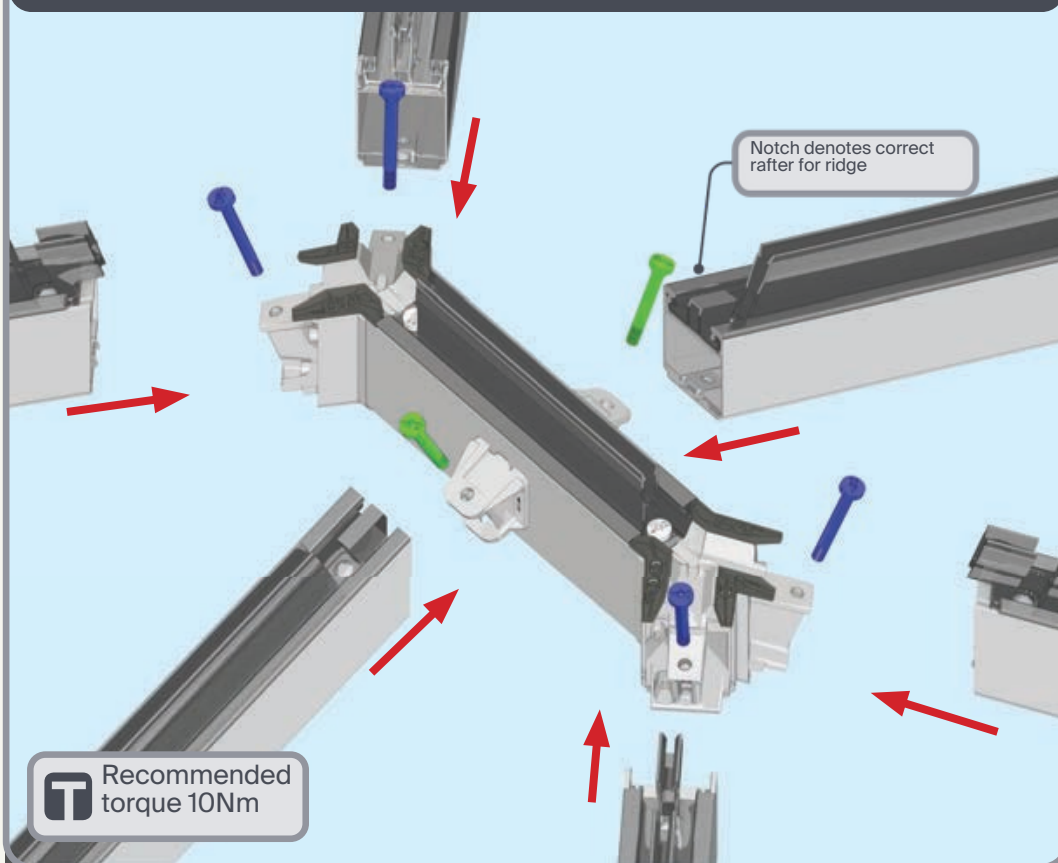

Boss variations

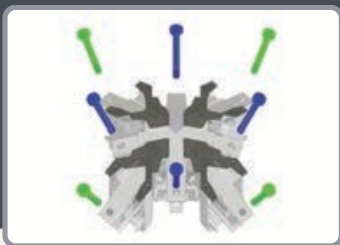

Ensure correct size bolts and tapered washers are used

JACK RAFTERS (OPTIONAL)

4

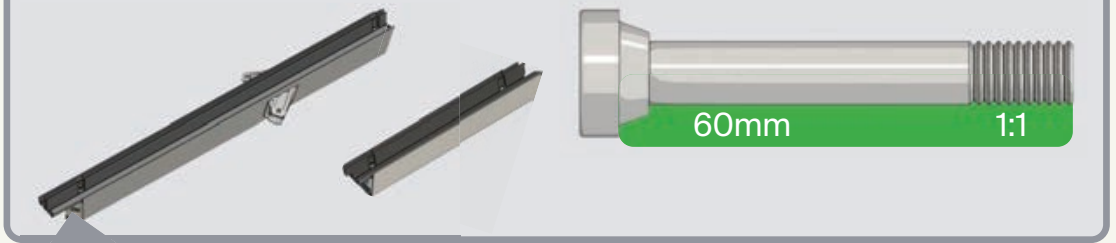

1 Raise hip if needed 2 Rotate into position

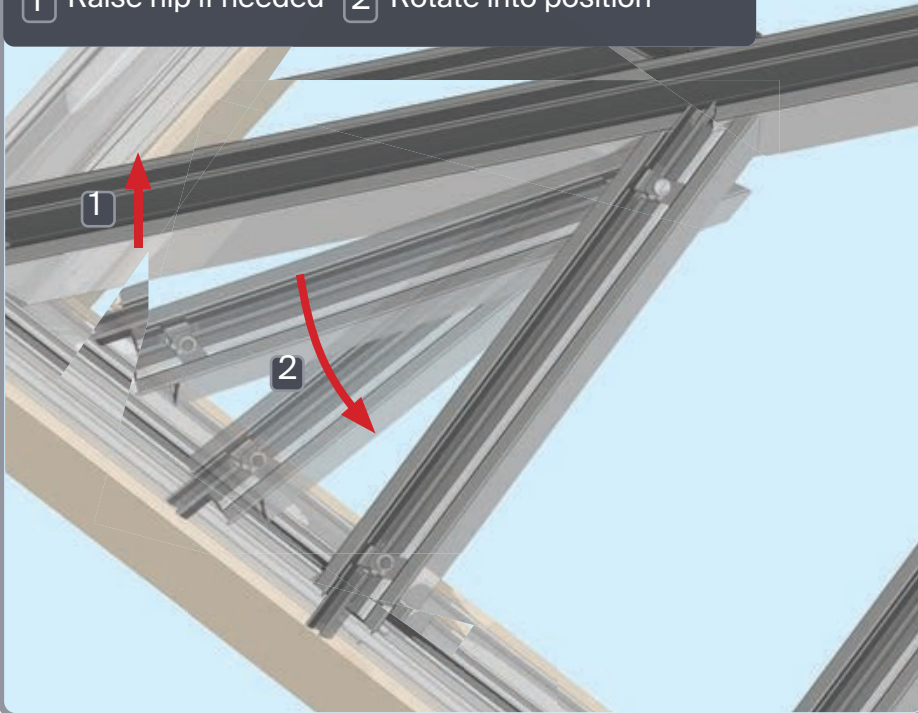

2 Secure using 60mm bolts

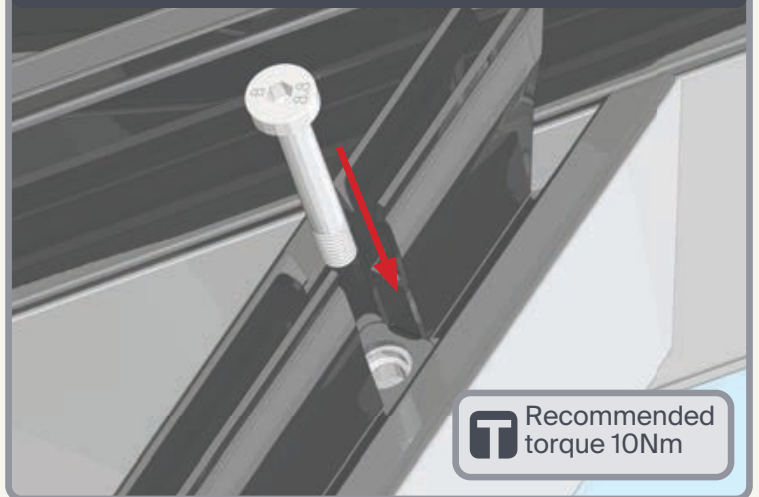

Ensure correct size bolts and tapered washers are used

ATTACHING SPIDER

5

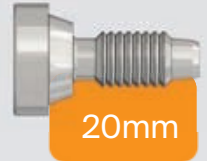

1 Loosely fit all 20mm bolts

2 Tighten bolts fully

3 Remove tie wraps

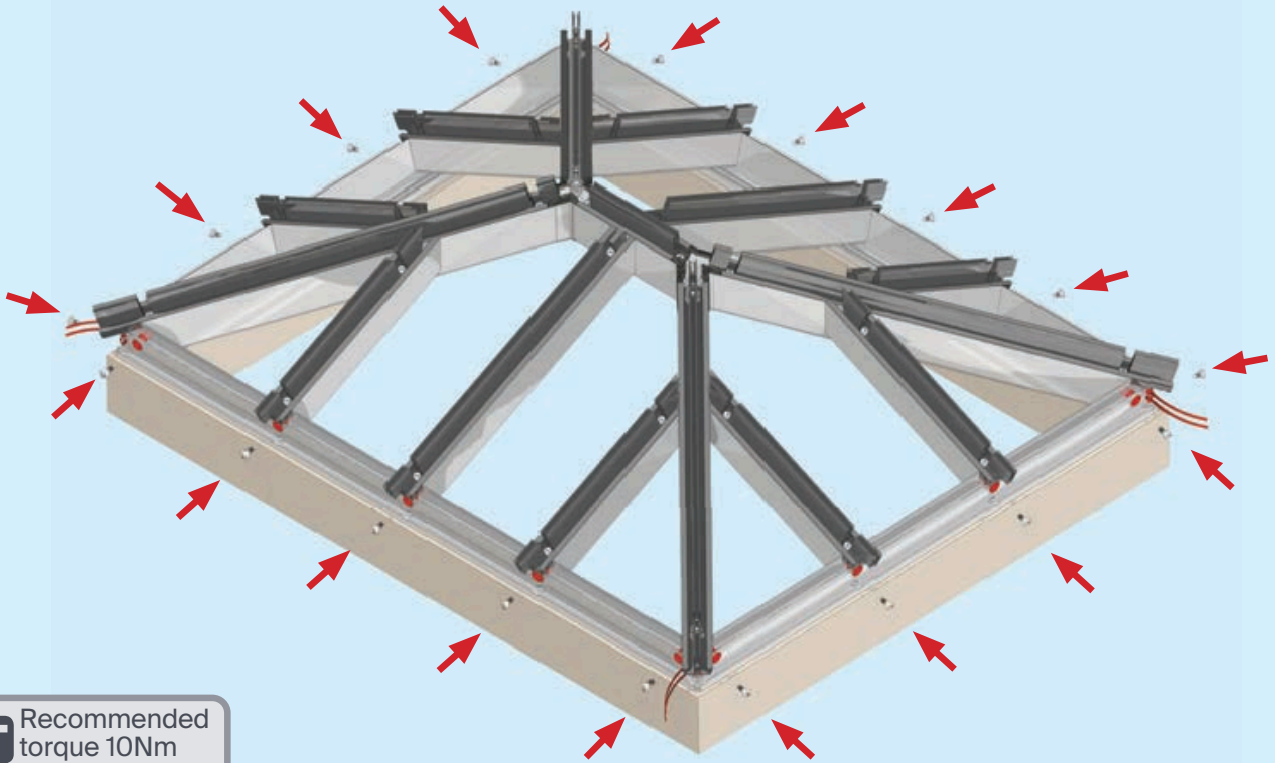

 Recommended torque 10Nm

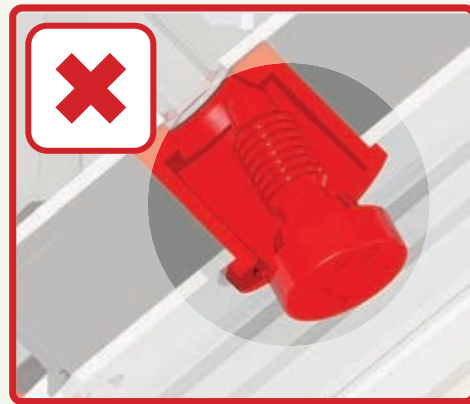
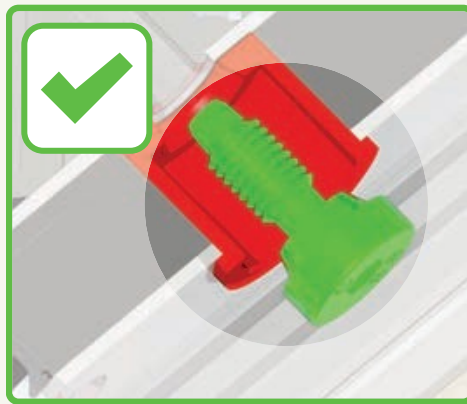

BEWARE not to cross thread bolts when fastening

FIXING DOWN

6

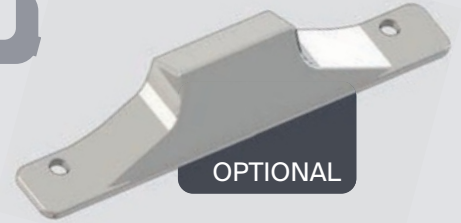

1 Position if supplied

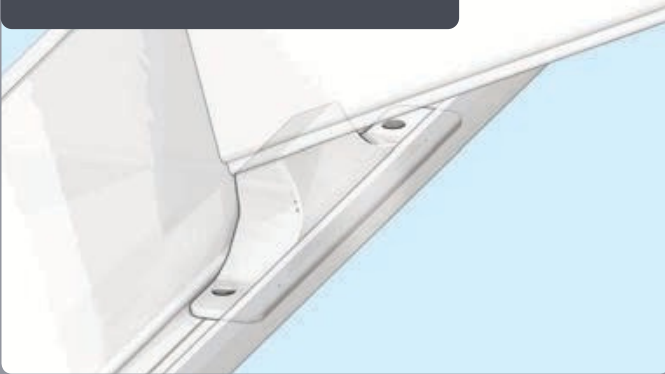

2 Fasten down through pre-drilled holes

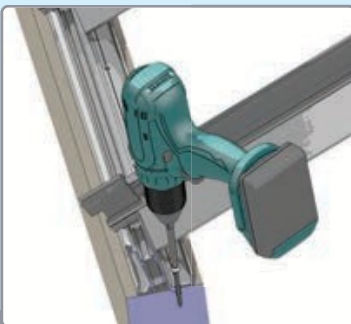
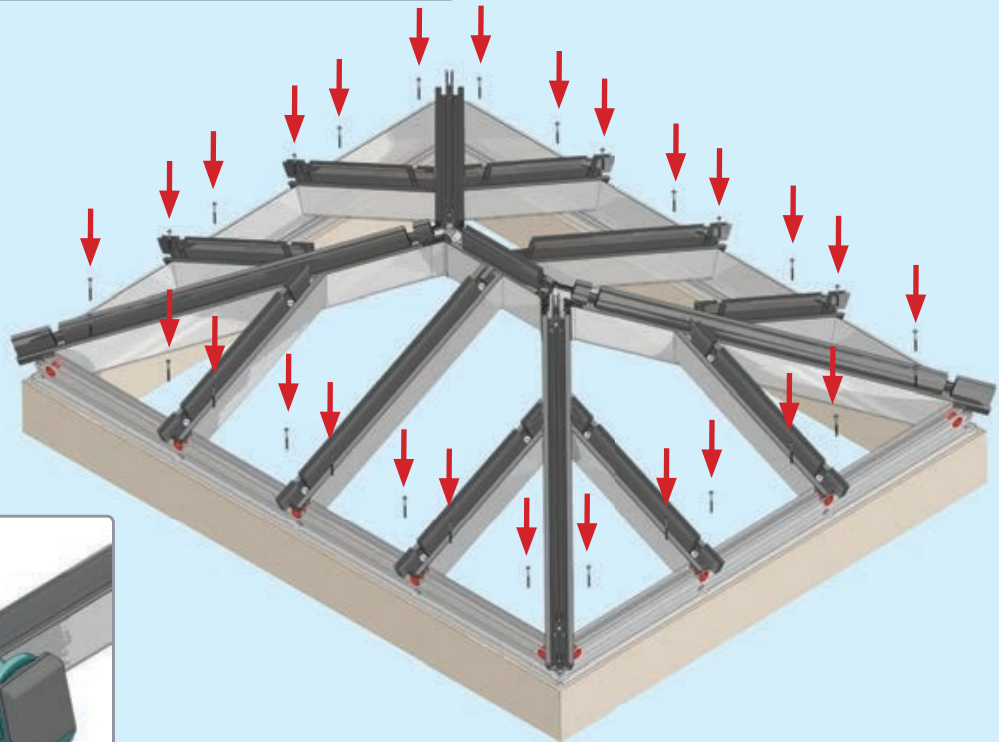

• USE packers under eaves beam to support each screw • CHECK eaves beams are fully sealed to upstand

GLASS RETAINER

7

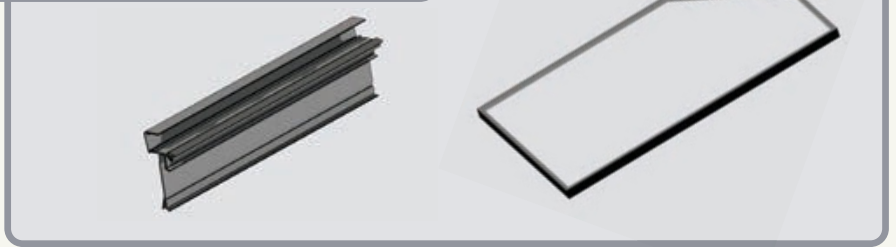

1 Slide glass into retainer

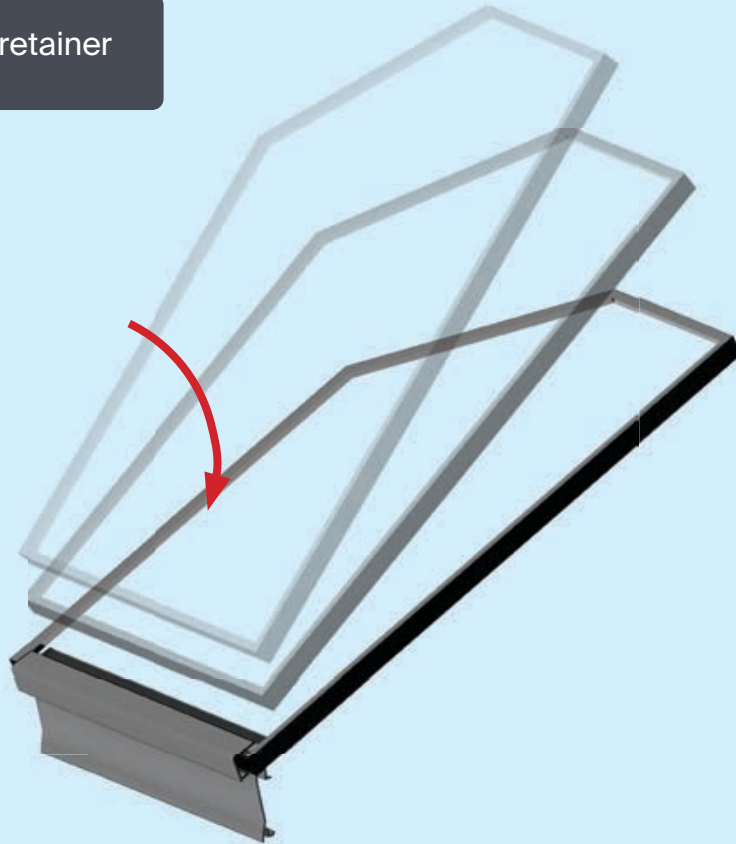

2 Set spacings as shown

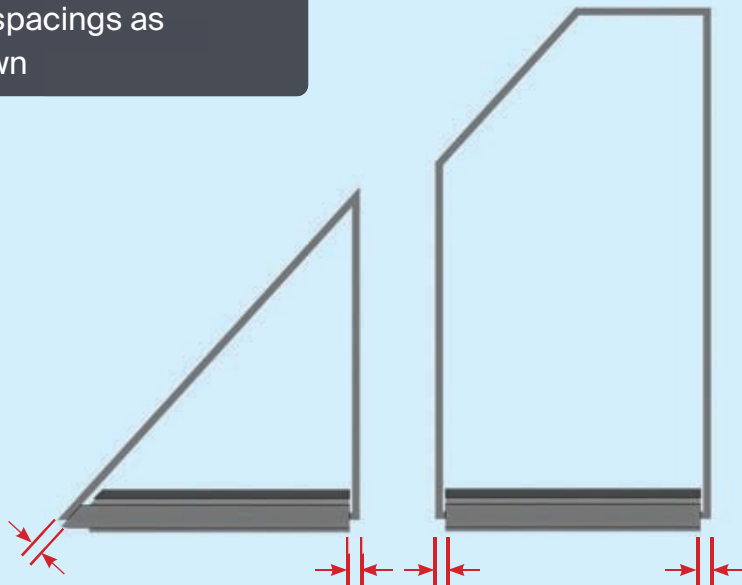

Dimensions shown approx 15mm

GLAZING

8

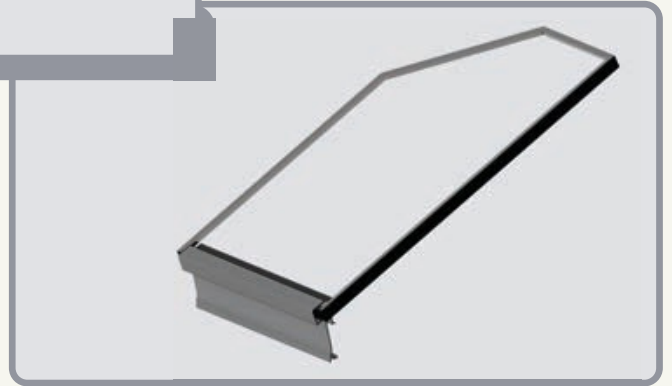

Locate top edge and rotate into position

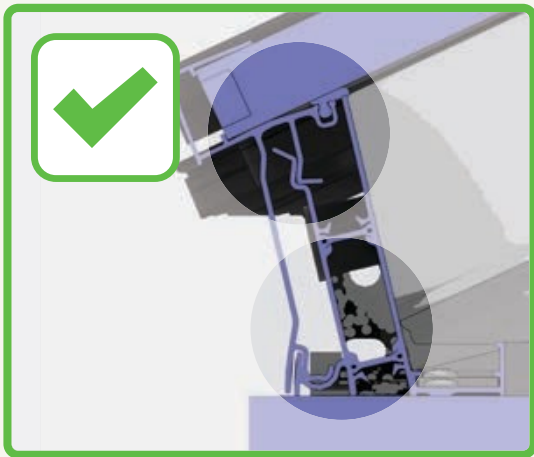
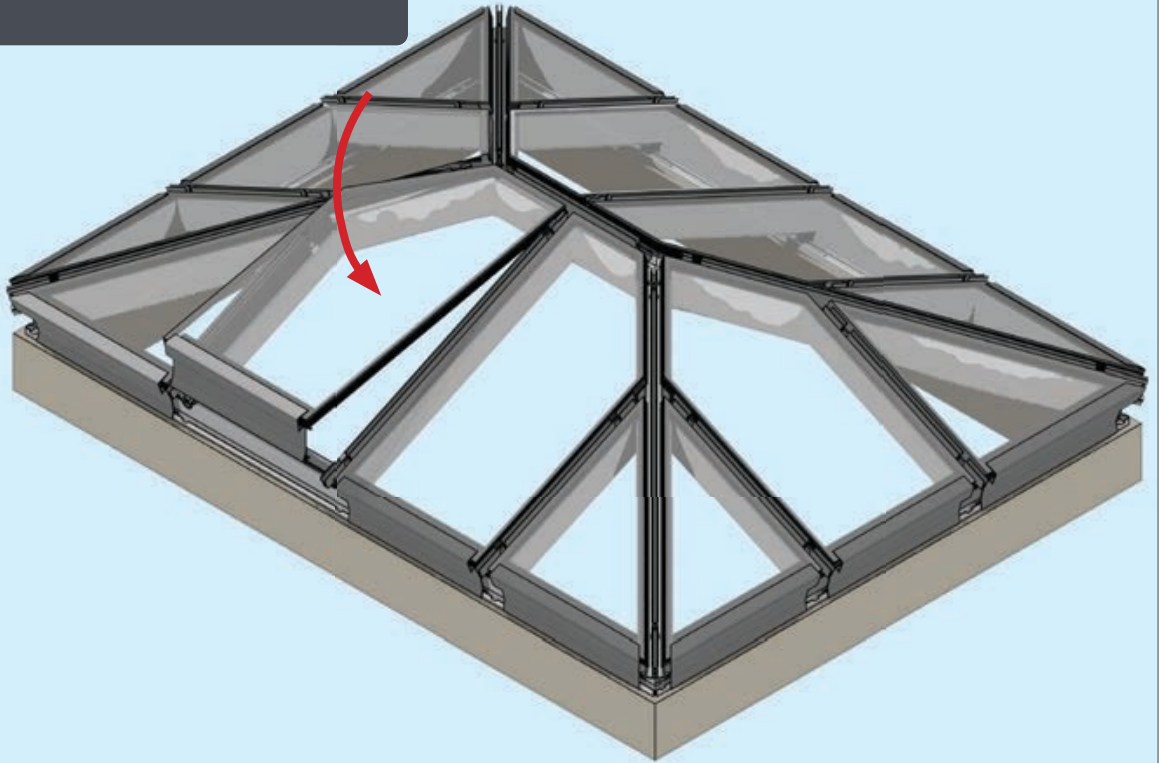

Ensure retainer is seated as shown

HIP LOWER ENDCAP

9



1

Adjust glass
retainer

2

Rotate into
position

3

Use mallet to fit
clips

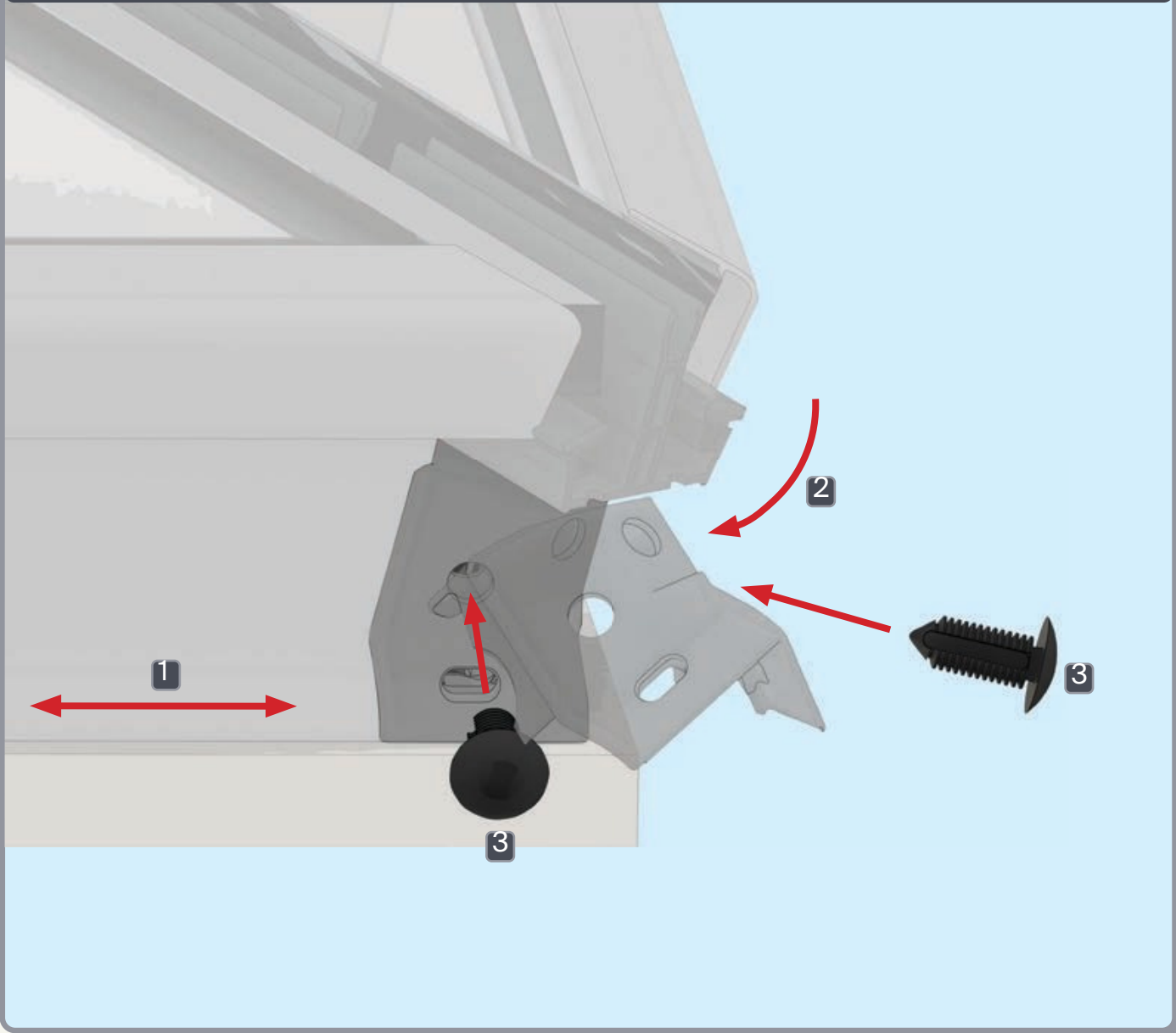

LOWER RAFTER ENDCAPS

10



1 Adjust glass retainer

2 Rotate into position

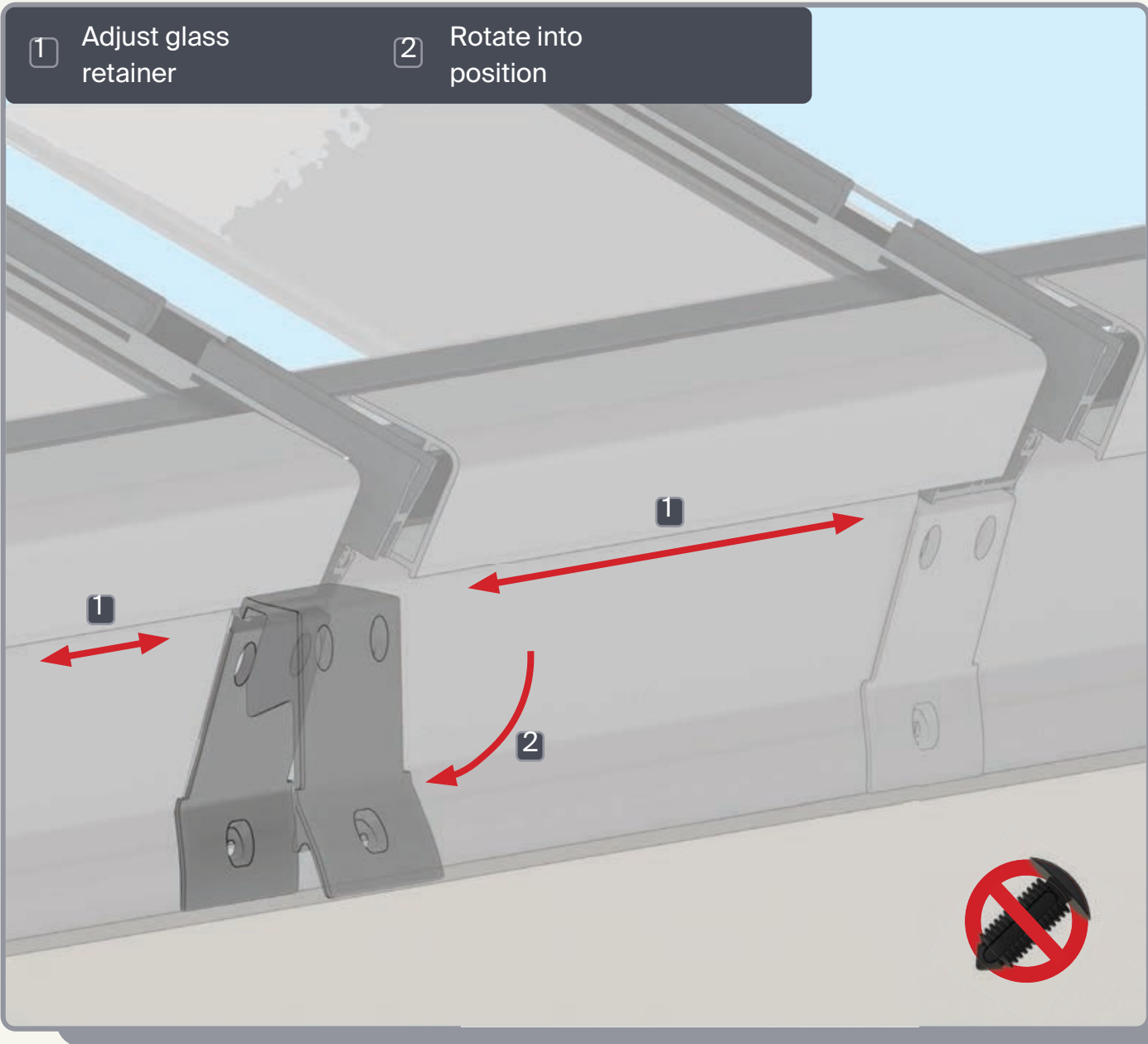

RIDGE TOP CAP

11

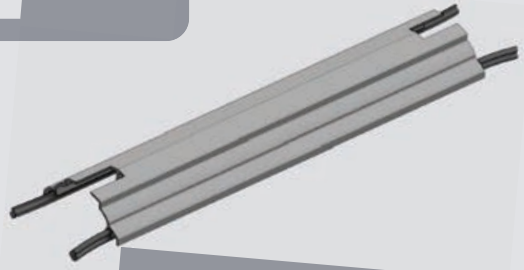

Clip top cap on to ridge and space centrally

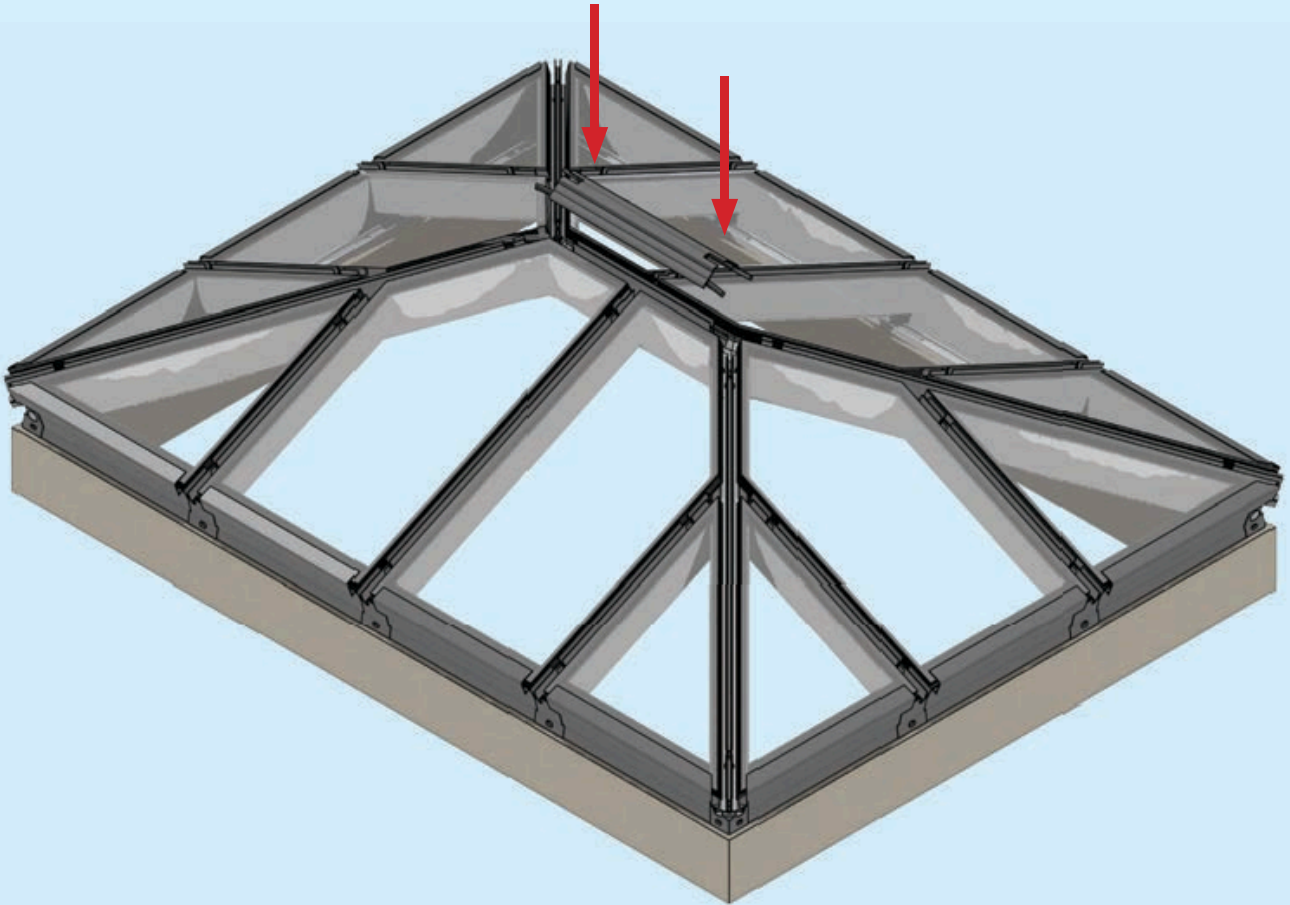

Leave gaskets
overlong

HIP TOP CAPS

12



Clip top caps on to hips

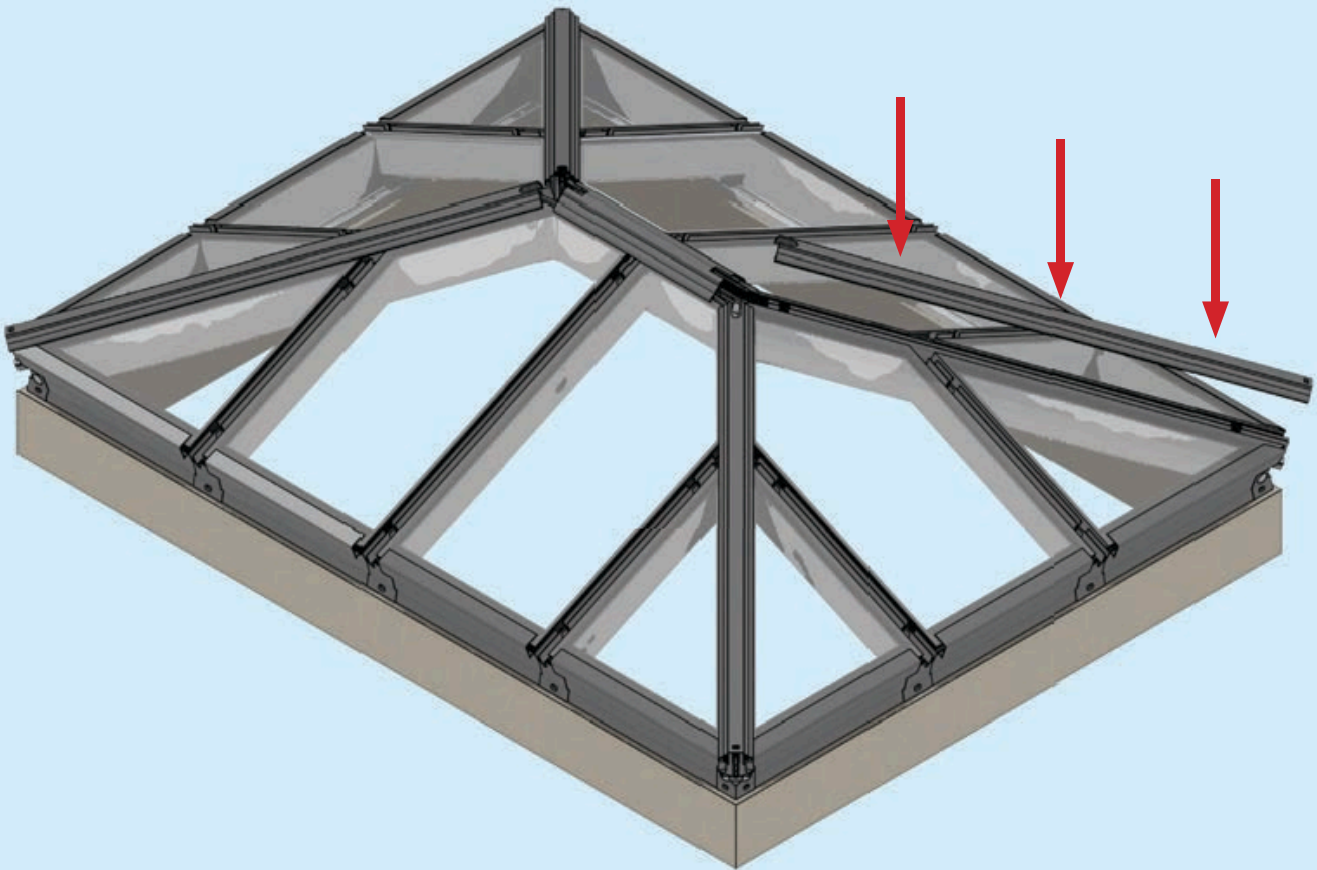

Ensure top cap lower end aligns with the lower end of hip

RAFTER TOP CAP

13



1 Clip top caps on to rafters

2 Tap up into position

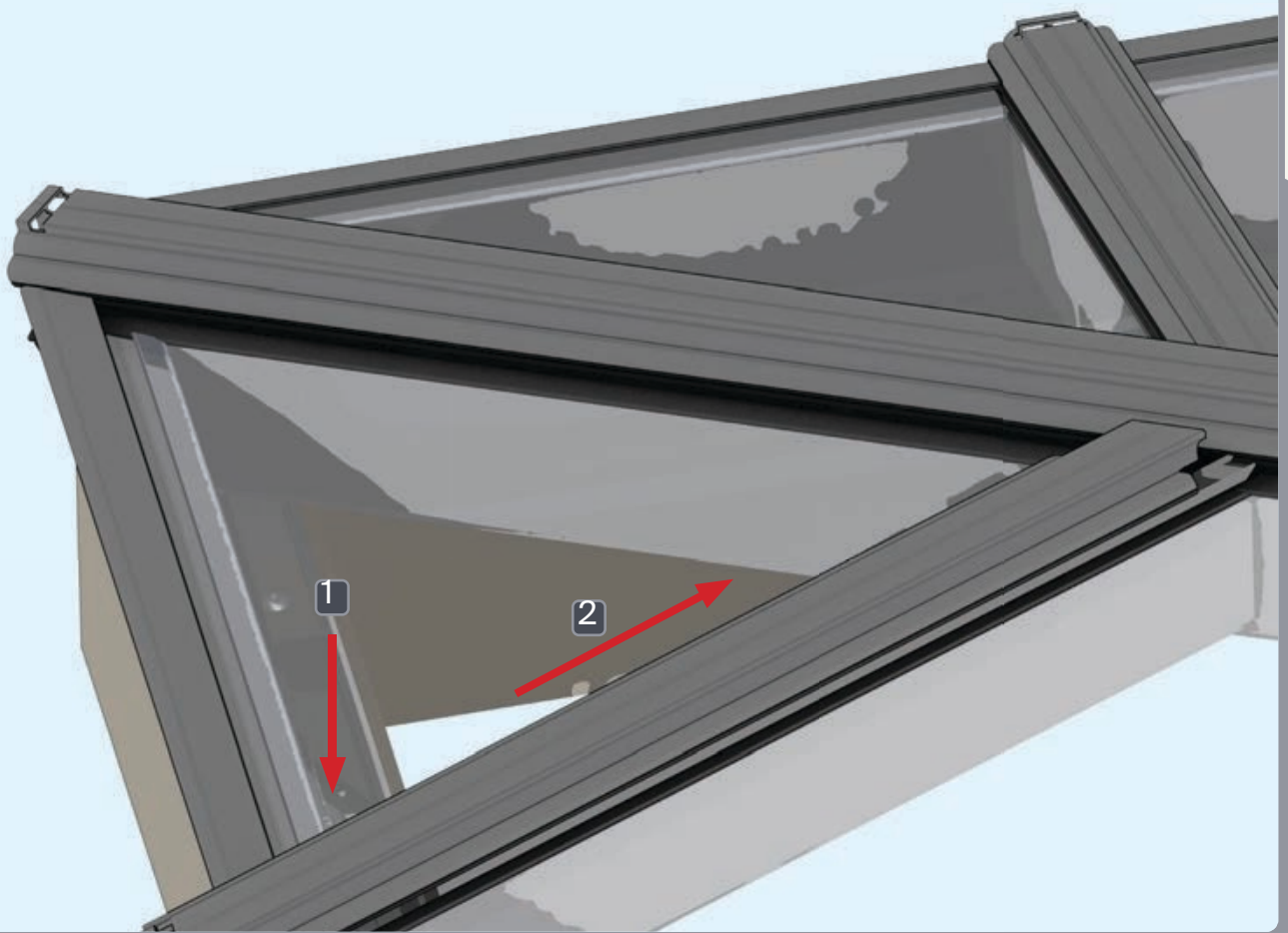

Ensure top cap lower end aligns with lower end of rafter

BOSS TOP CAPS

14

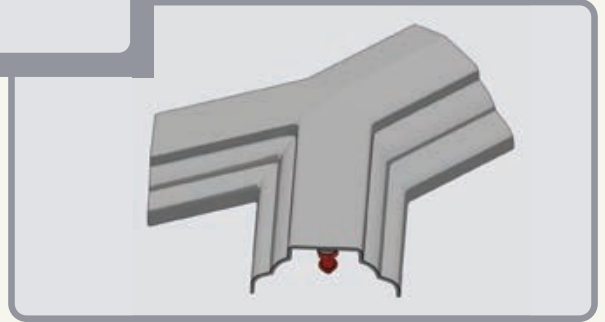

Clip in to position

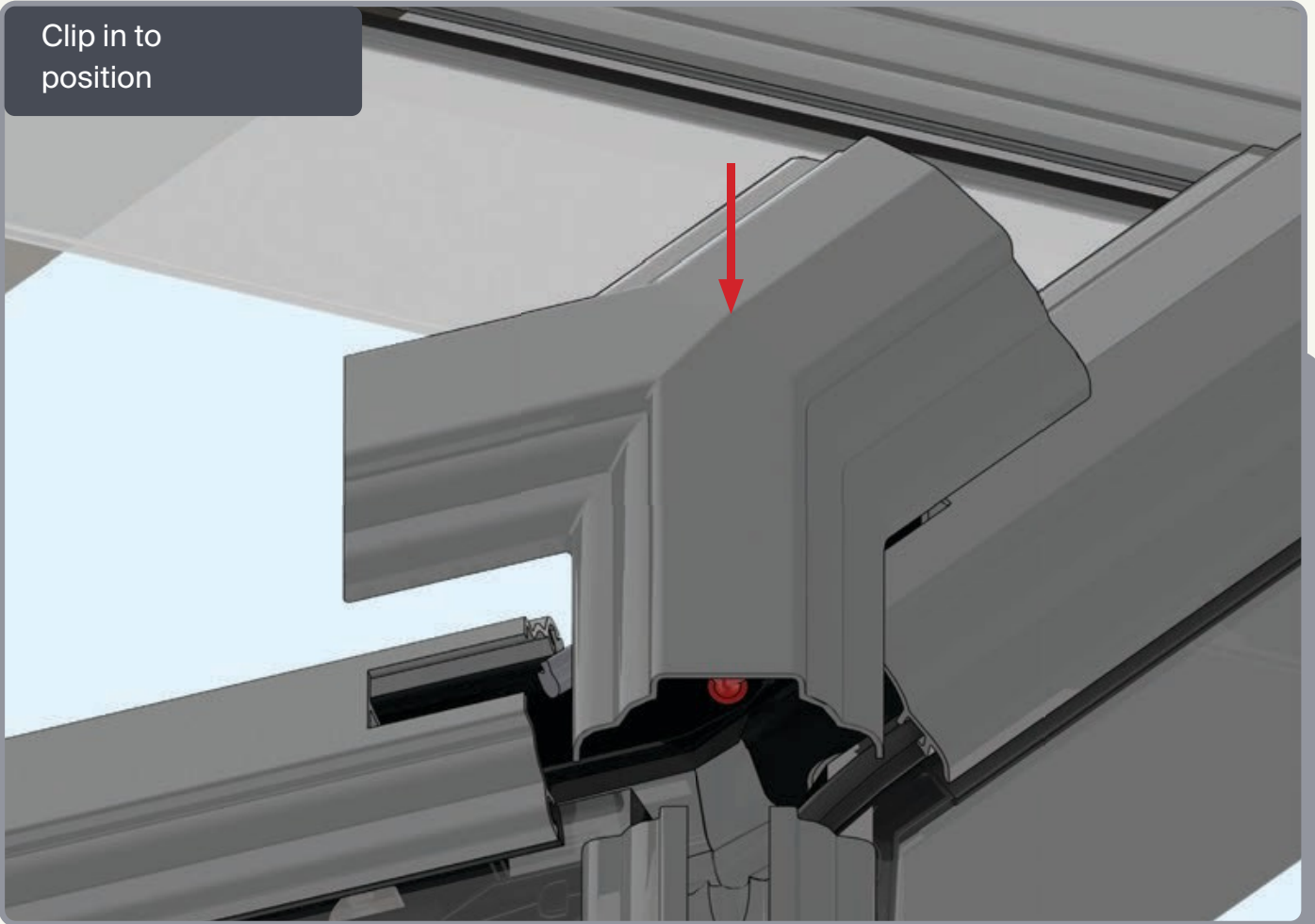

Variations



HIP UPPER-END CAPS

15



1 Fit fir tree clips to end caps



2 Push end caps onto ends of hips

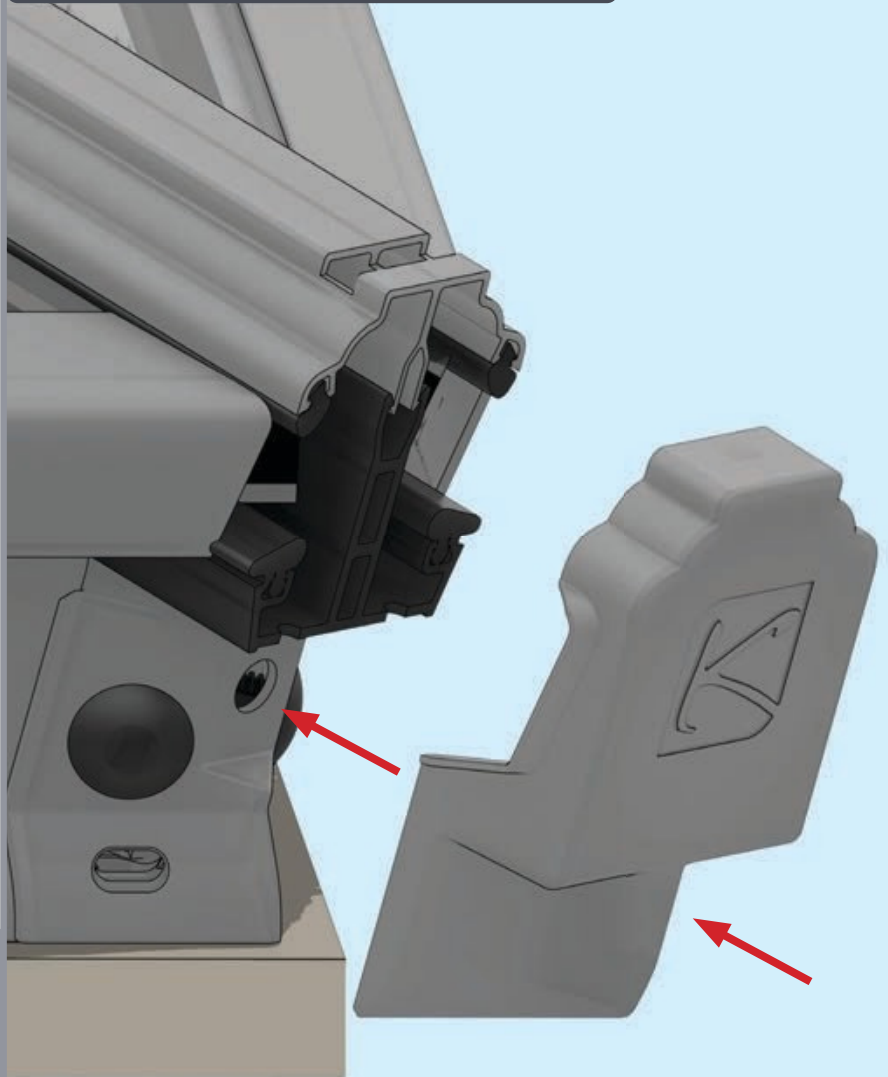

16

RAFTER UPPER END CAPS

16



1 Fit fir tree clips to end caps

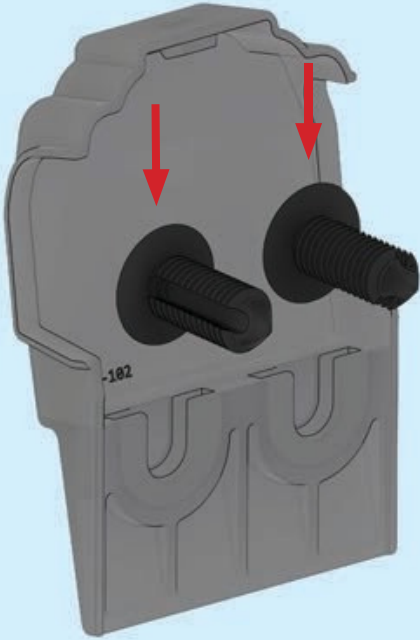

2 Push end caps onto ends of rafters

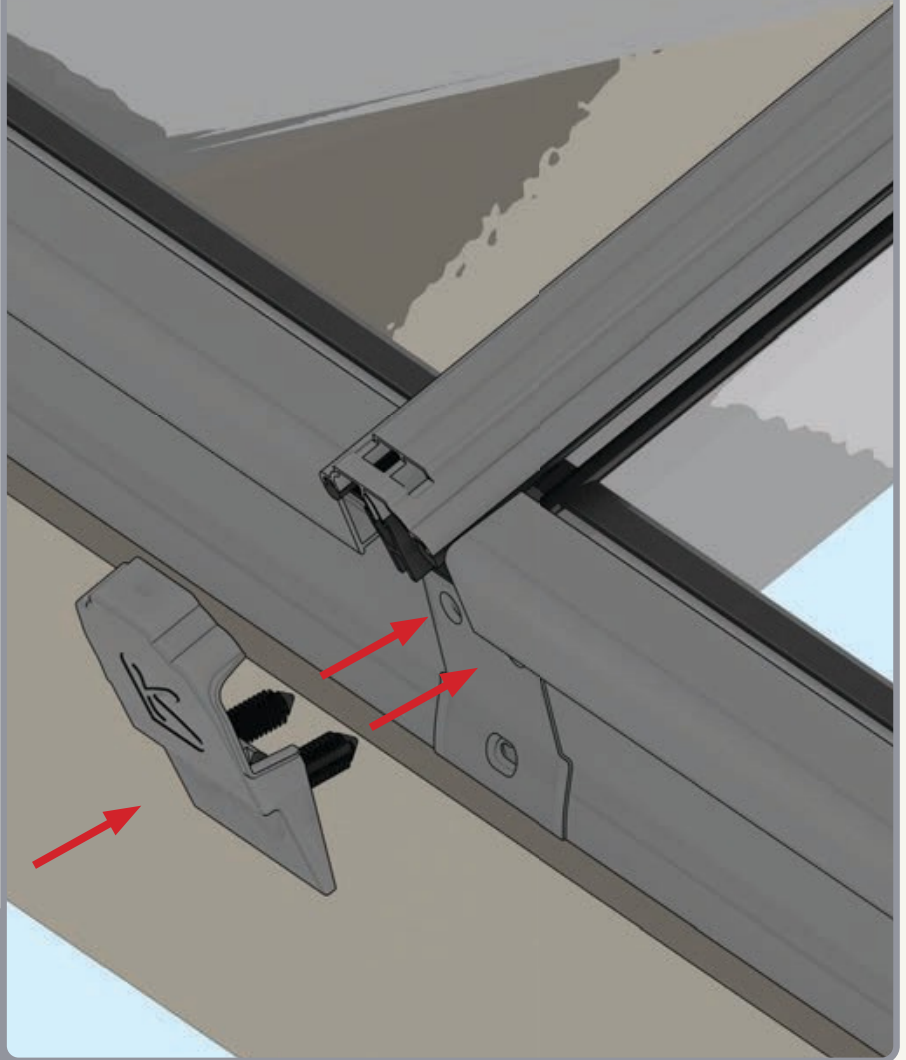

COMPONENTS LIST



RAFTER RIDGE LUG
KLC-100



RAFTER EAVES LUG
KLC-101



RAFTER OUTER END CAP
KLC-102



RAFTER INNER END CAP
KLC-103



HIP OUTER END CAP
KLC-105



HIP INNER ENDCAP
KLC-106



HIP EAVES LUG
KLC-107



2 WAY BOSS TOP CAP
KLC-108



2 WAY BOSS TOP CAP FOR FINIAL
KLC-108/F



3 WAY BOSS TOP CAP
KLC-109



3 WAY BOSS TOP CAP FOR FINIAL
KLC-109/F



BOSS TOP CAP PIN
KLC-110



EAVES BEAM CORNER ISOLATING BRACKET
KLC-111



COLLAR
KLC-112



TWO WAY END BOSS
KLC-113



THREE WAY END BOSS
KLC-114



JACK RAFTER LUG LEFT
KLC-115



JACK RAFTER LUG RIGHT
KLC-116



BALL FINIAL
KLC-117



B2B FOUR WAY BOSS
KLC-119



B2B EIGHT WAY BOSS
KLC-120



B2B FOUR WAY BOSS TOP CAP
KLC-121



B2B FOUR WAY BOSS TOP CAP FOR FINIAL
KLC-121/F



B2B EIGHT WAY BOSS TOP CAP
KLC-122



B2B EIGHT WAY BOSS TOP CAP FOR FINIAL
KLC-122/F



RAFTER SUPPORT BLOCK
KLC-123



CHIMNEY NUT M8
KLF-300



EAVES BEAM SCREW
KLF-301



BOLT M8 X 70
KLF-303



TAPERED WASHER M8
KLF-304



BOLT M8 X 60
KLF-305



FIR TREE CLIP
KLF-306



BOLT M8 X 20
KLF-307



SERRATED FLANGE NUT M8
KLF-311



TIE WRAP
KLF-315



EAVES BEAM / T-BAR QLON GASKET
KLG-200



TOP CAP QLON GASKET
KLG-201



BOSS CENTRAL GASKET W/CENTER RAFTER
KLG-202



BOSS CENTRAL GASKET
KLG-203



BOSS LEFT GASKET
KLG-204



BOSS RIGHT GASKET
KLG-205



HEX TOOL
KLT-01

COMPONENTS LIST

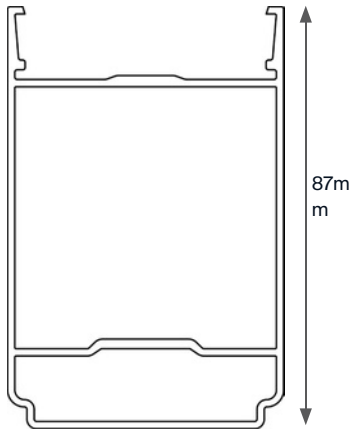

RIDGE
BODY
KLP-01

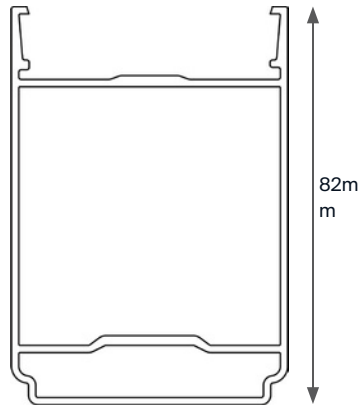

HIP
BODY
KLP-02

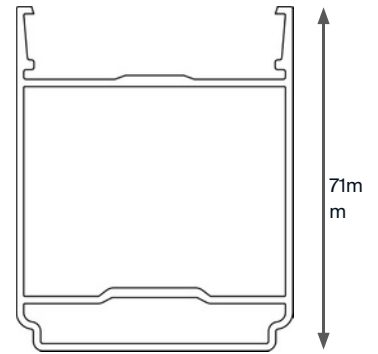

RAFTER
BODY
KLP-03

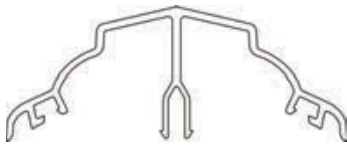

RIDGE TOP
CAP
KLP-06

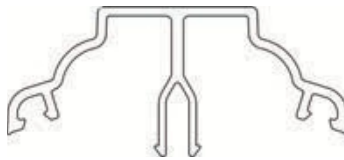

HIP TOP
CAP
KLP-07

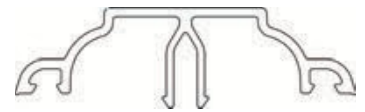

RAFTER TOP
CAP
KLP-08

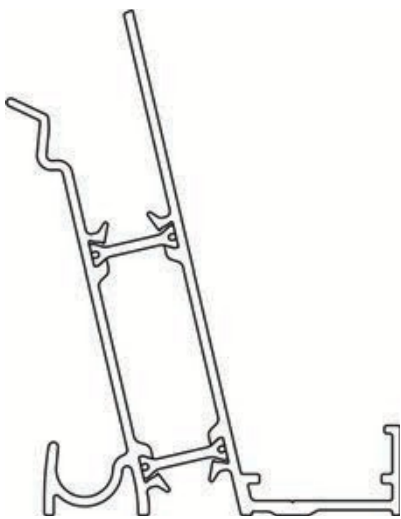

EAVES
BEAM
KLP-05

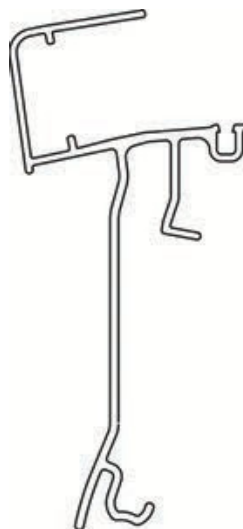

GLASS
RETAINER
KLP-04

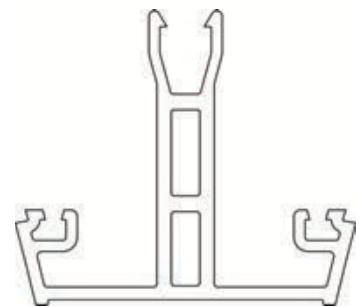

THERMAL T
BAR
KLP-09



WWW.VALUEDOORS.CO.UK | PHONE 020 4587 8300